

5.2 - Exploded views

This part of the manual contains a selection of exploded views, which will assist in gaining a thorough knowledge of the machine.

5.2.1 - Head assembly

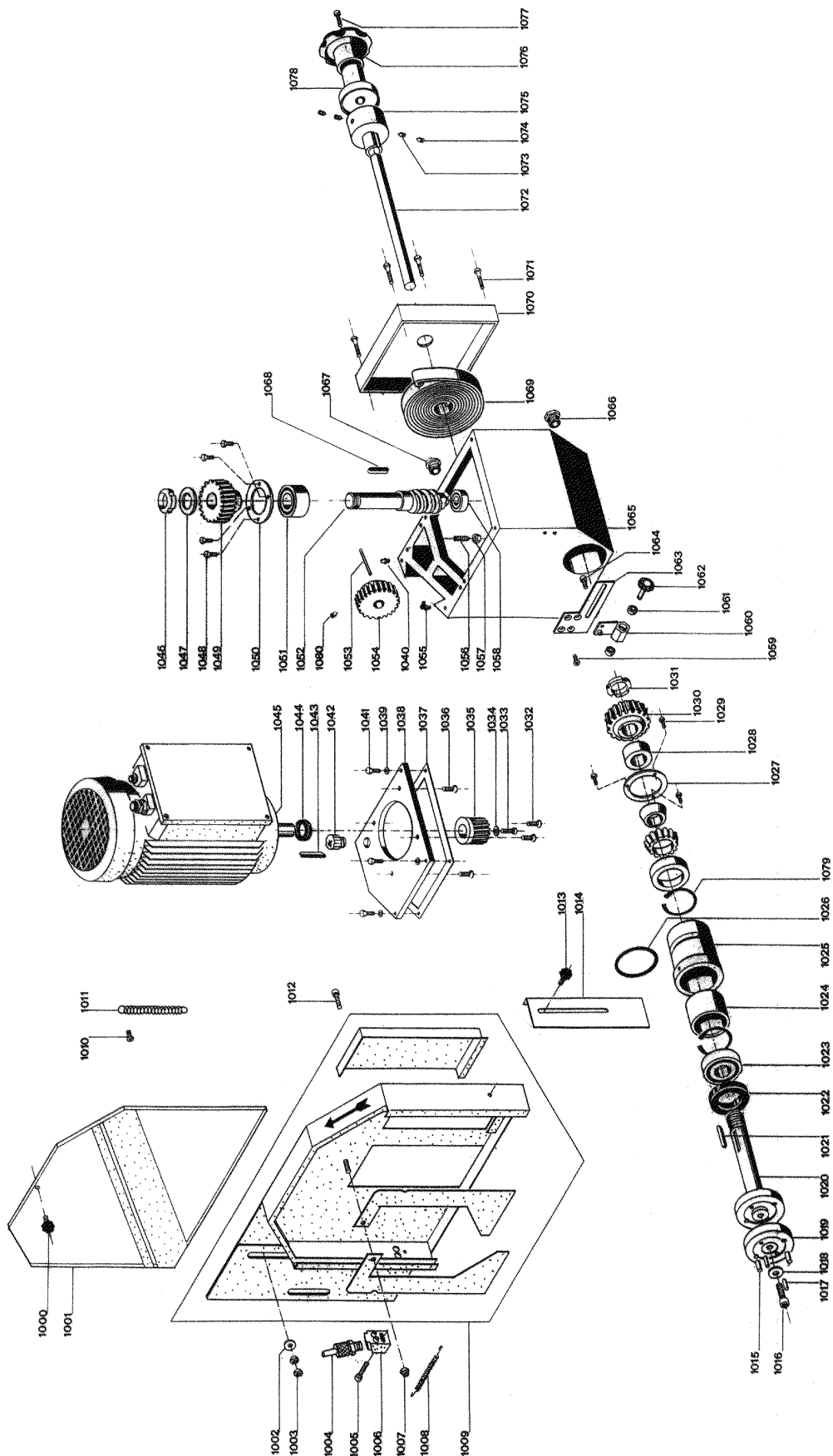

5.2.2 - Vice assembly

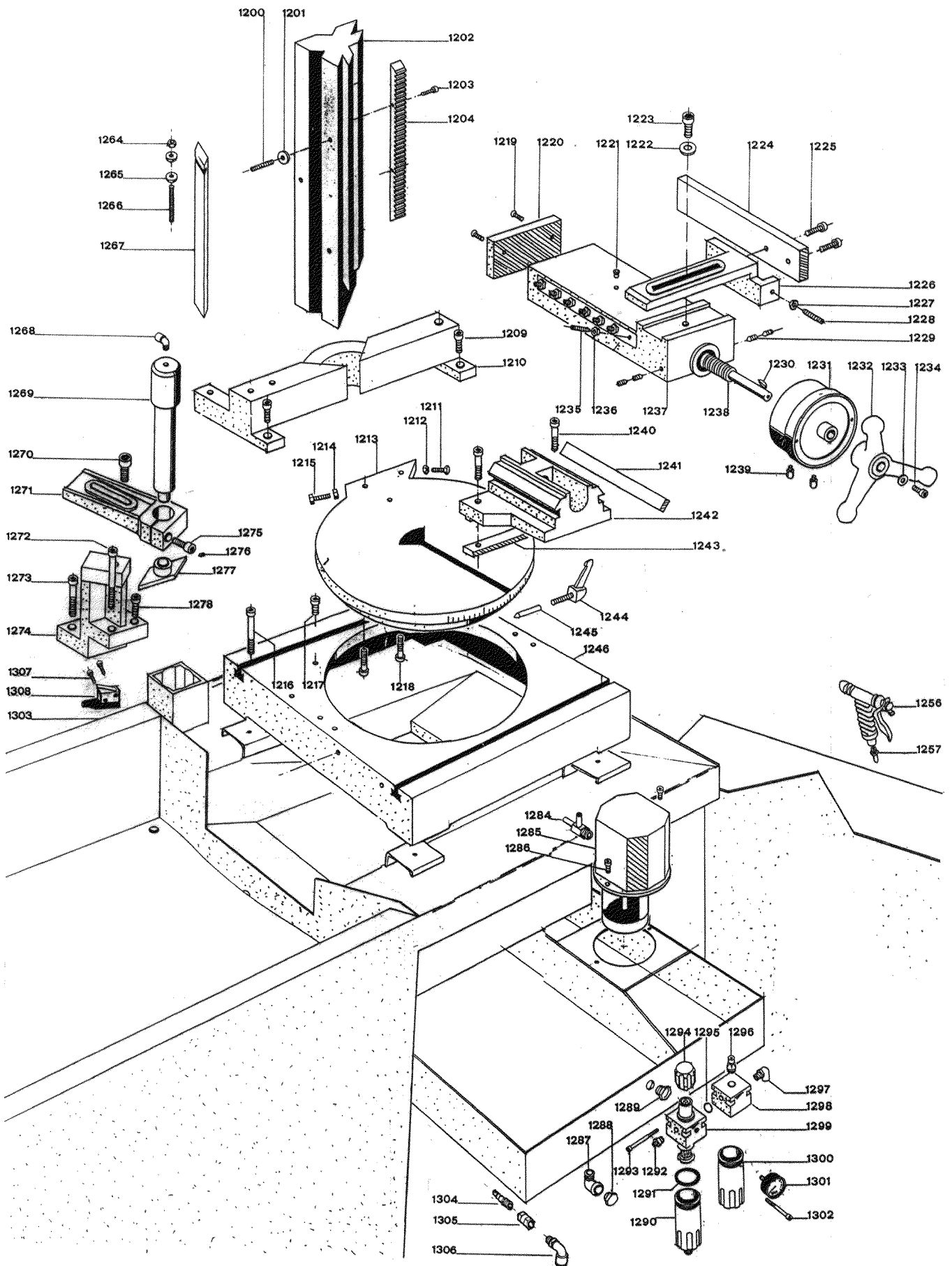

5.2.3 - Programming and control console

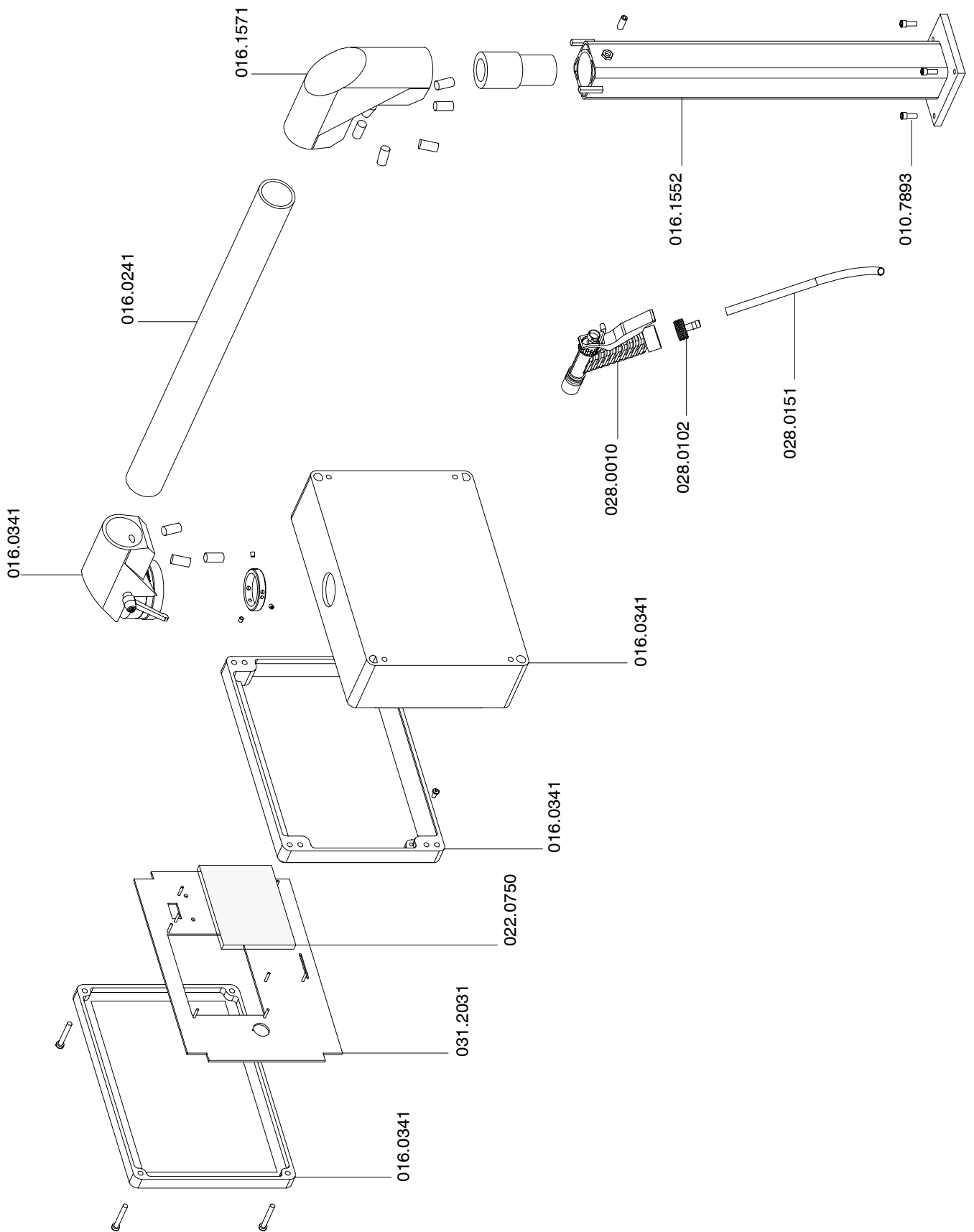

5.2.4 - Hydraulic cylinder

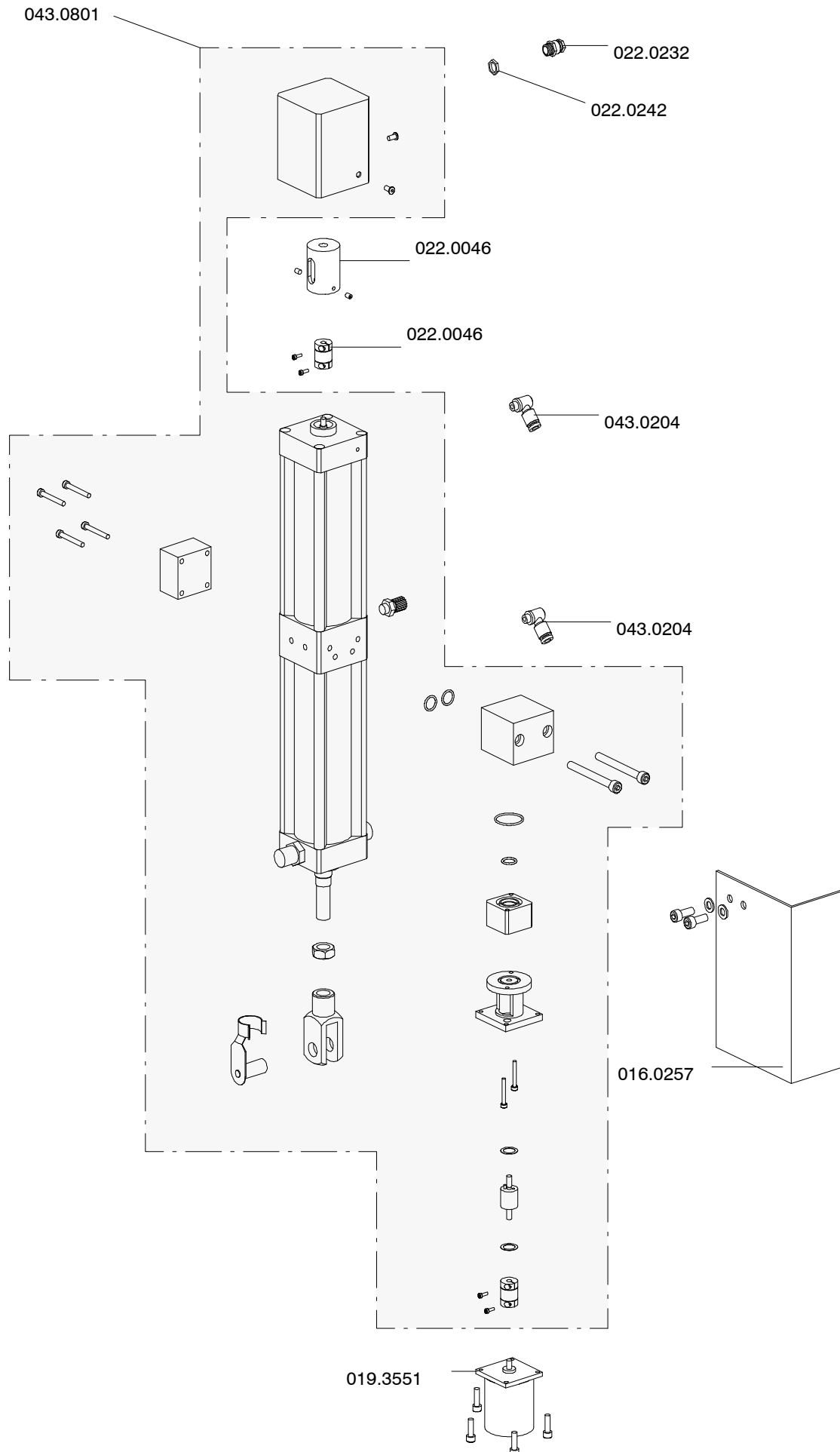

5.2.5 - Feeder

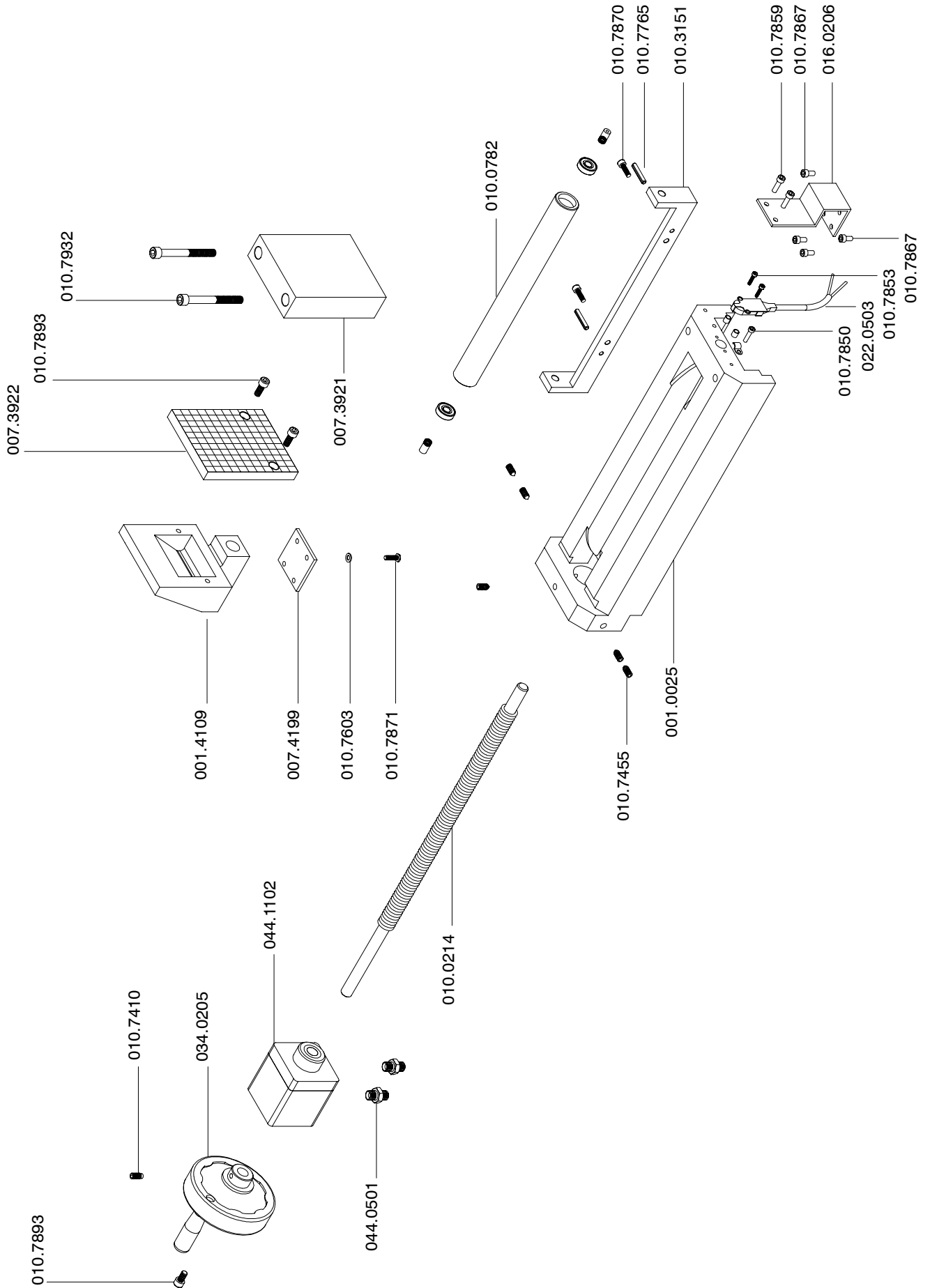

Feeder (cont.d)

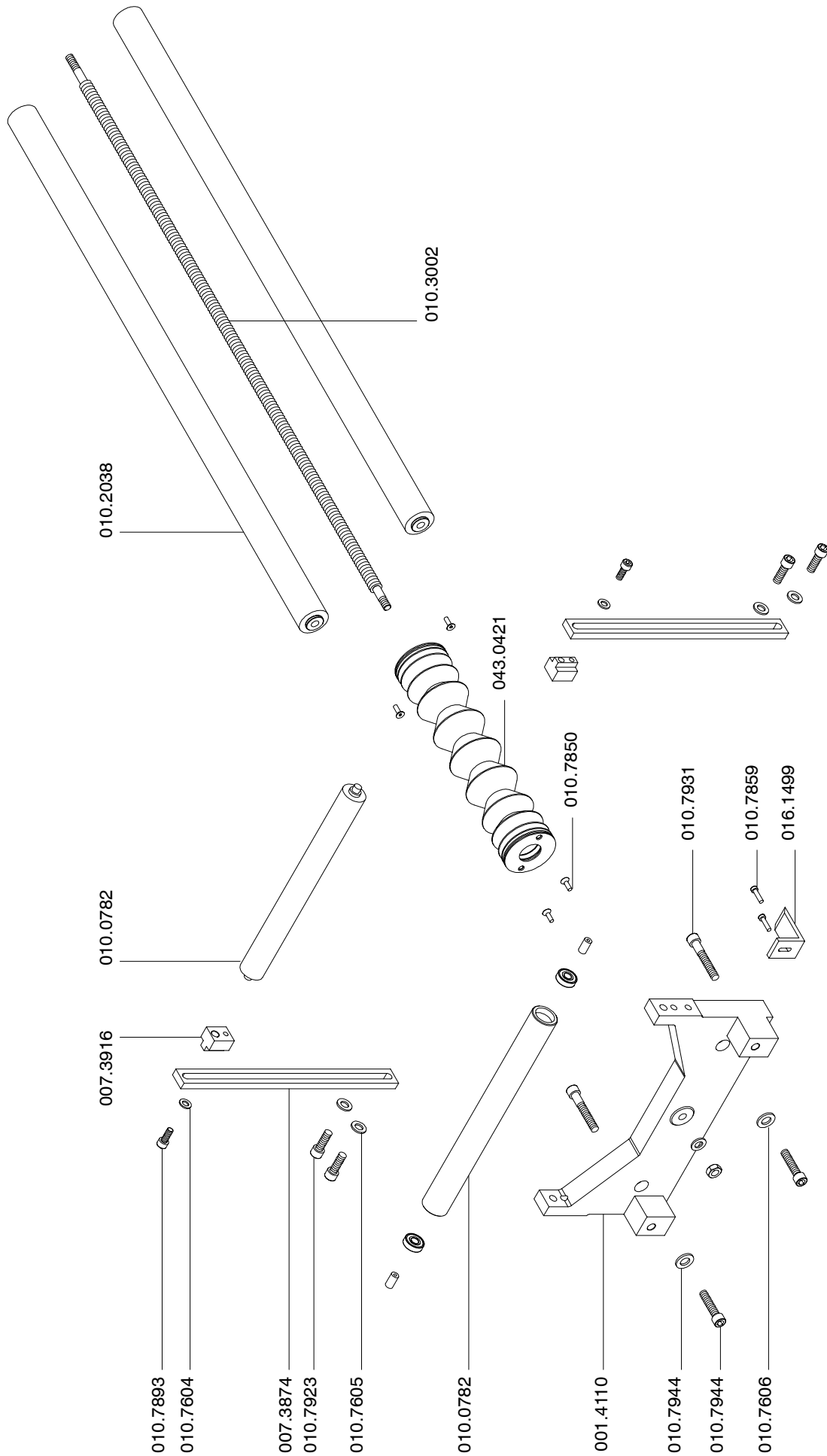

Feeder (cont.d)

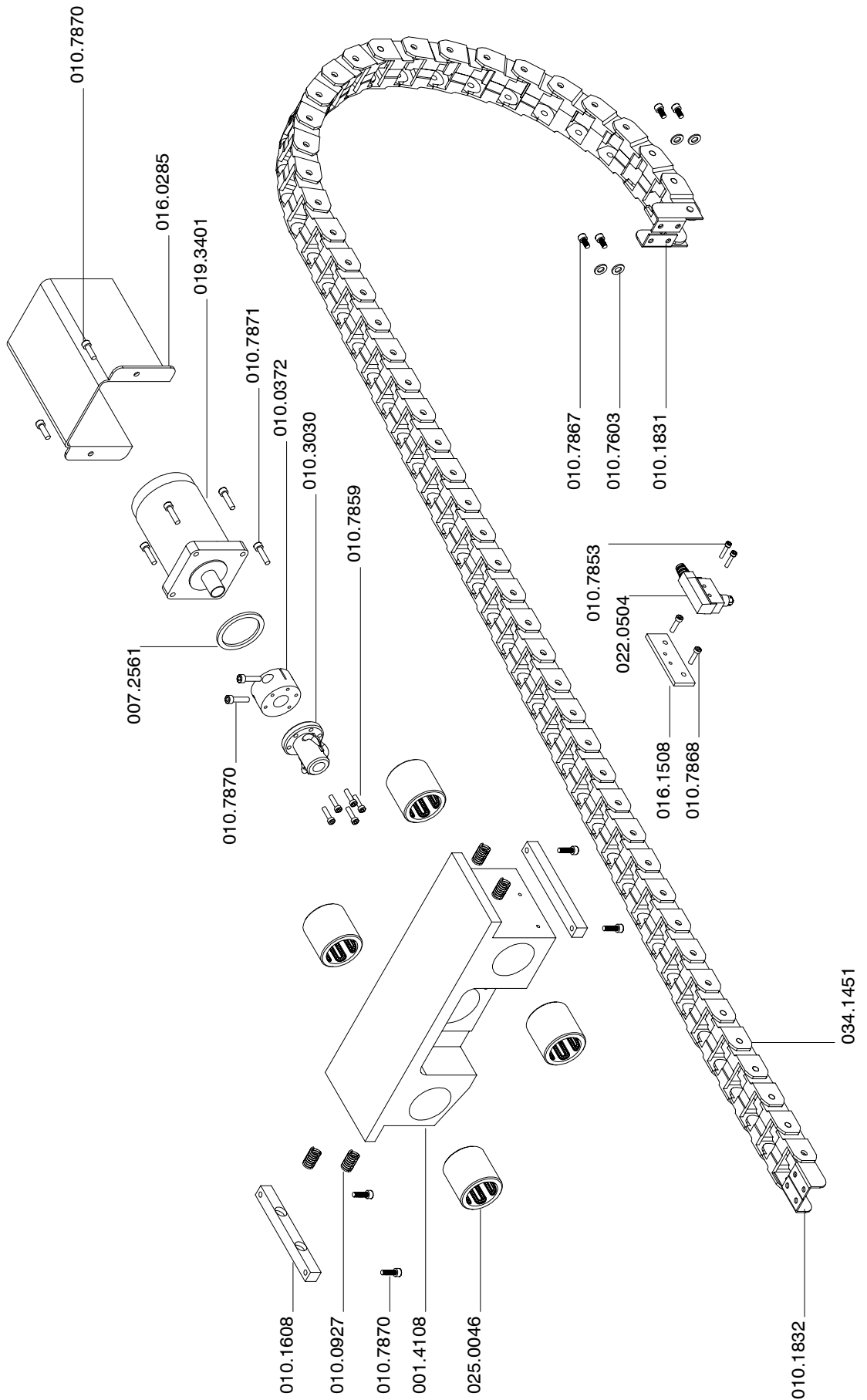

Feeder (cont.d)

